

MATERIAL

Hardened steel (53+6 HRC).

STANDARD EXECUTIONS

- **DIN 6321-B:** positioning element with cone-shaped head cylinder.
- **DIN 6321-C:** positioning element with faceted head.

FEATURES AND APPLICATIONS

DIN 6321-B is suitable to be used as a sliding surface, a clamp or as a levelling element.

DIN 6321-C are generally used to compensate tolerances in distance between positioning holes, thanks to their design and faceted head.

Application example

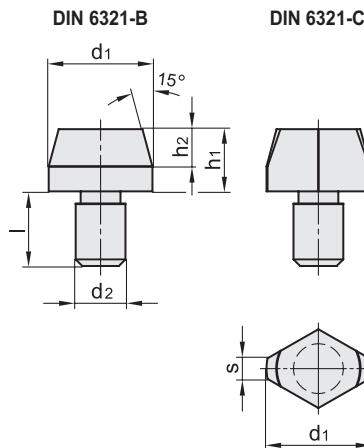
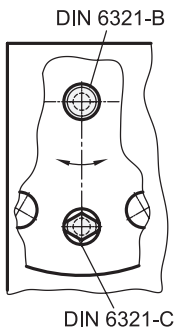

Conversion Table	
1 mm = 0.039 inch	
d1	
mm	inch
6	0.24
8	0.31
10	0.39
12	0.47
16	0.63
20	0.79
25	0.98

DIN 6321-B

METRIC

Code	Description	d1	h1 ±0.1	d2 n6	h2	l	△
GN.13051	DIN 6321-6-7-B	6	7	4	4	6	2
GN.13053	DIN 6321-6-12-B	6	12	4	4	6	3
GN.13055	DIN 6321-8-10-B	8	10	6	6	9	5
GN.13057	DIN 6321-8-16-B	8	16	6	6	9	7
GN.13059	DIN 6321-10-10-B	10	10	6	6	9	7
GN.13061	DIN 6321-10-18-B	10	18	6	6	9	12
GN.13063	DIN 6321-12-10-B	12	10	6	6	9	10
GN.13065	DIN 6321-12-18-B	12	18	6	6	9	17
GN.13067	DIN 6321-16-13-B	16	13	8	8	12	22
GN.13069	DIN 6321-16-22-B	16	22	8	8	12	36
GN.13071	DIN 6321-20-15-B	20	15	12	9	18	47
GN.13073	DIN 6321-20-25-B	20	25	12	9	18	72
GN.13075	DIN 6321-25-15-B	25	15	12	9	18	66
GN.13077	DIN 6321-25-25-B	25	25	12	9	18	105

DIN 6321-C

METRIC

Code	Description	d1	h1 ±0.1	d2 n6	h2	l	s	△
GN.13052	DIN 6321-6-7-C	6	7	4	4	6	1	3
GN.13054	DIN 6321-6-12-C	6	12	4	4	6	1	4
GN.13056	DIN 6321-8-10-C	8	10	4.6	6	9	1.6	4
GN.13058	DIN 6321-8-16-C	8	16	4.6	6	9	1.6	5
GN.13060	DIN 6321-10-10-C	10	10	6	6	9	2.5	6
GN.13062	DIN 6321-10-18-C	10	18	6	6	9	2.5	9
GN.13064	DIN 6321-12-10-C	12	10	6	6	9	2.5	7
GN.13066	DIN 6321-12-18-C	12	18	6	6	9	2.5	11
GN.13068	DIN 6321-16-13-C	16	13	8	8	12	3.5	17
GN.13070	DIN 6321-16-22-C	16	22	8	8	12	3.5	25
GN.13072	DIN 6321-20-15-C	20	15	12	9	18	5	39
GN.13074	DIN 6321-20-25-C	20	25	12	9	18	5	55
GN.13076	DIN 6321-25-15-C	25	15	12	9	18	5	49
GN.13078	DIN 6321-25-25-C	25	25	12	9	18	5	72



Machine elements